

Biogas Blower



"Burning for a Better Environment..."

<http://www.bke.co.th>
contact@bke.co.th

Model: BW 20-40 HP

- Factory Engineered
- Stainless Steel Body
- Automatic Operation
- Economical and Safe
- Low Maintenance
- 100% Compatible with BKE Control Unit
- 24 Months Factory Guarantee

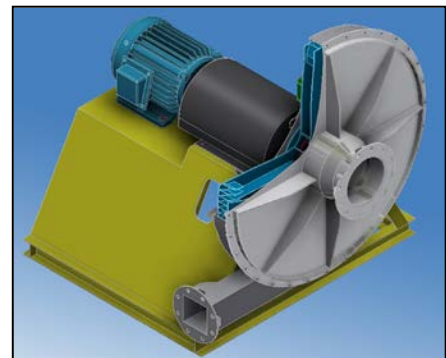
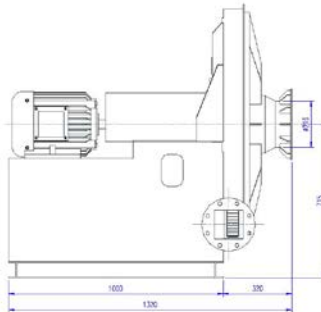
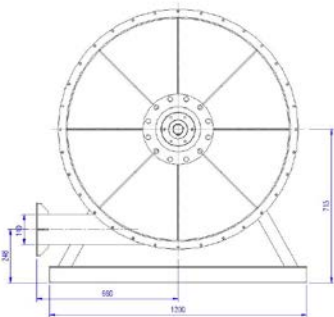

BKE Biogas Blower Technical Specifications:	
Blower Type:	Centrifugal Blower
Motor:	20-40 HP, 50 Hz, 380 Volt, 3 Phase, (IP 55)
Rotational Speed:	2,850 RPM (Maximum)
Materials:	<ul style="list-style-type: none"> - Stainless Steel Fan & Casing - Carbon Steel Support - Hardened Carbon Steel Shaft & Hub - Rubber Seal with Automatic Greasing for Shaft & Housing
Max Operating Pressure:	120 mbar/set at 2,000 Nm ³ /h
Optional:	Additional Inverter and/or BKE Control Unit

Pressure Flow Rate

Model: BW 20 HP

Performance Curve

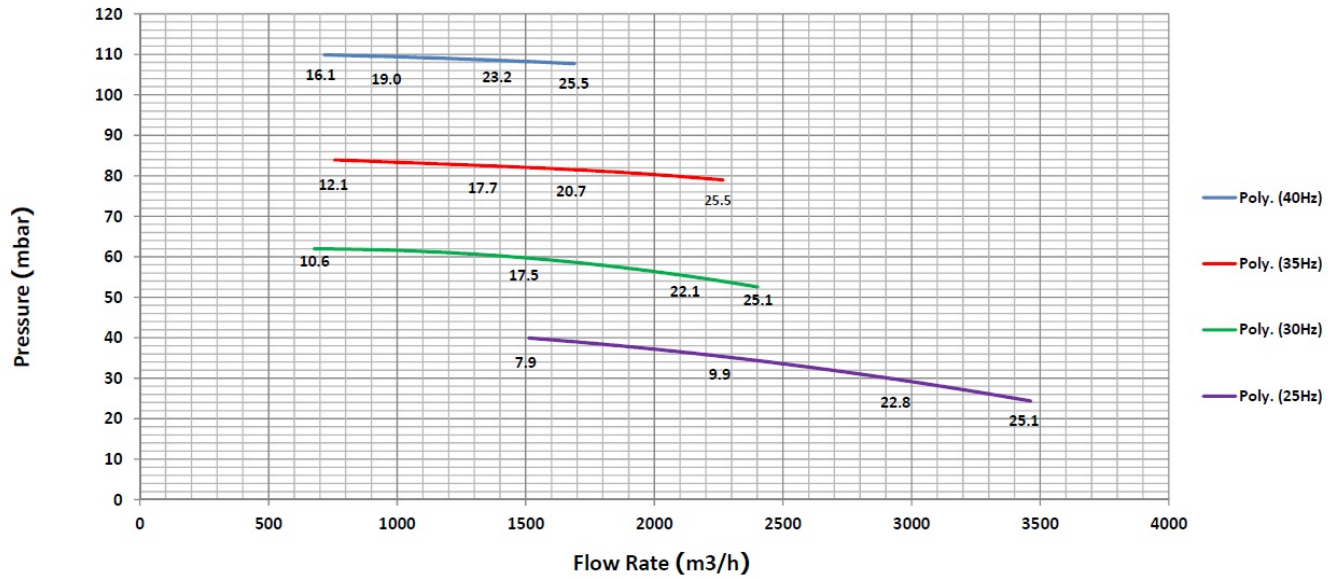

**The number shown in the graph are Quantity of Electrical unit (Ampere)



32 Phakam Rd, Tambon Huawieng, Amphur Muang
Lampang 52000 THAILAND
Tel: (66) 54 228680-1 Fax: (66) 54 227802
website: <http://www.bke.co.th> email: contact@bke.co.th